

PERIMETER
SURVEYING & MAPPING
 Certificate of Authorization No. LB7264
 Prepared by: Jeff S. Hodapp, P.S.M.
 951 Broken Sound Parkway, Suite 320
 Boca Raton, Florida 33487
 Tel: (561) 241-9988
 Fax: (561) 241-6182

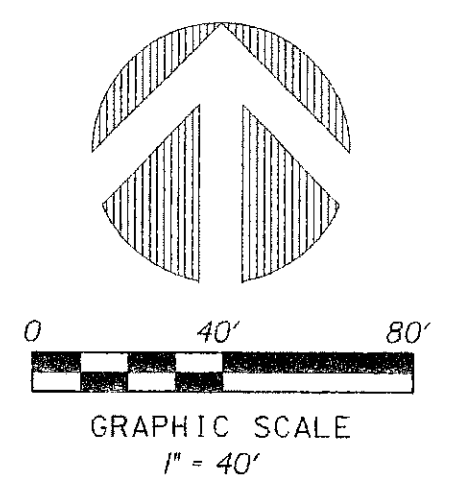

CAPISTARA P.U.D.

A REPLAT OF A PORTION OF THE SOUTHWEST ONE-QUARTER (INCLUDING PORTIONS OF TRACTS 9, 10 AND 11) OF "AMENDED PLAT OF SEC. 12 TWP. 45 S., R. 42 E., MARY A. LYMAN ET AL", (P.B. 9, PG. 74, P.B.C.R.), PALM BEACH COUNTY, FLORIDA.

JUNE, 2007

96

SHEET 2 OF 5

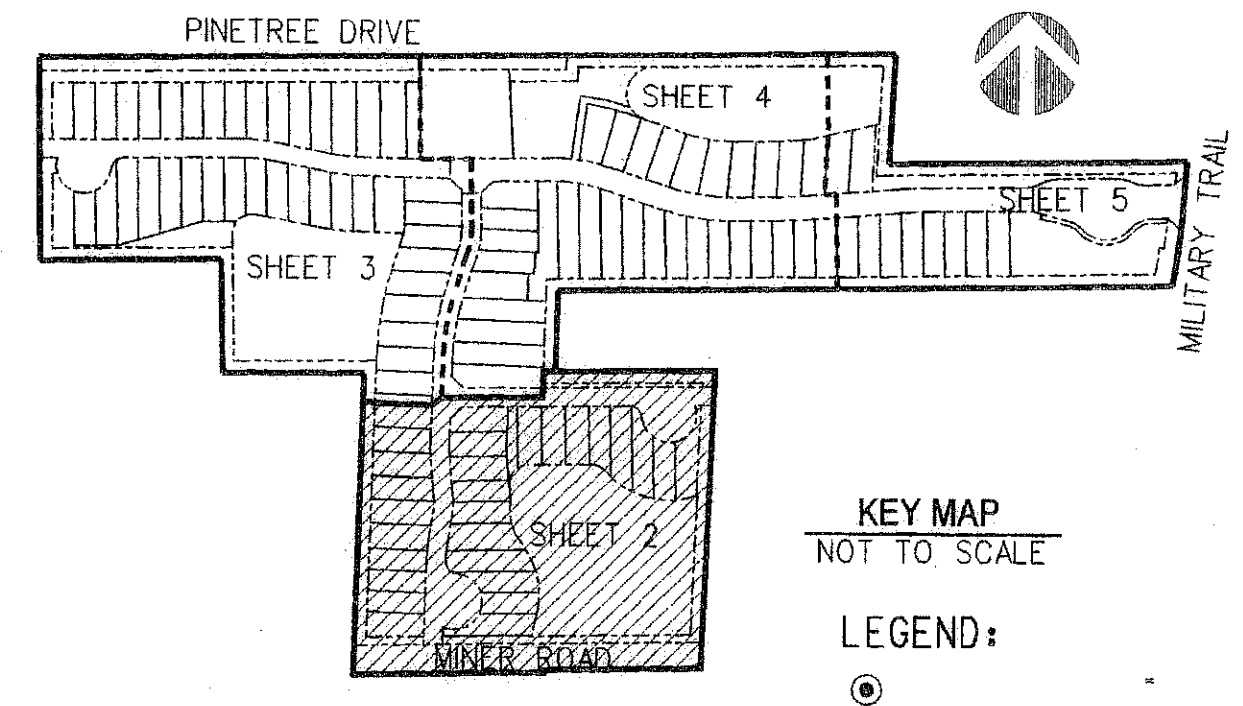
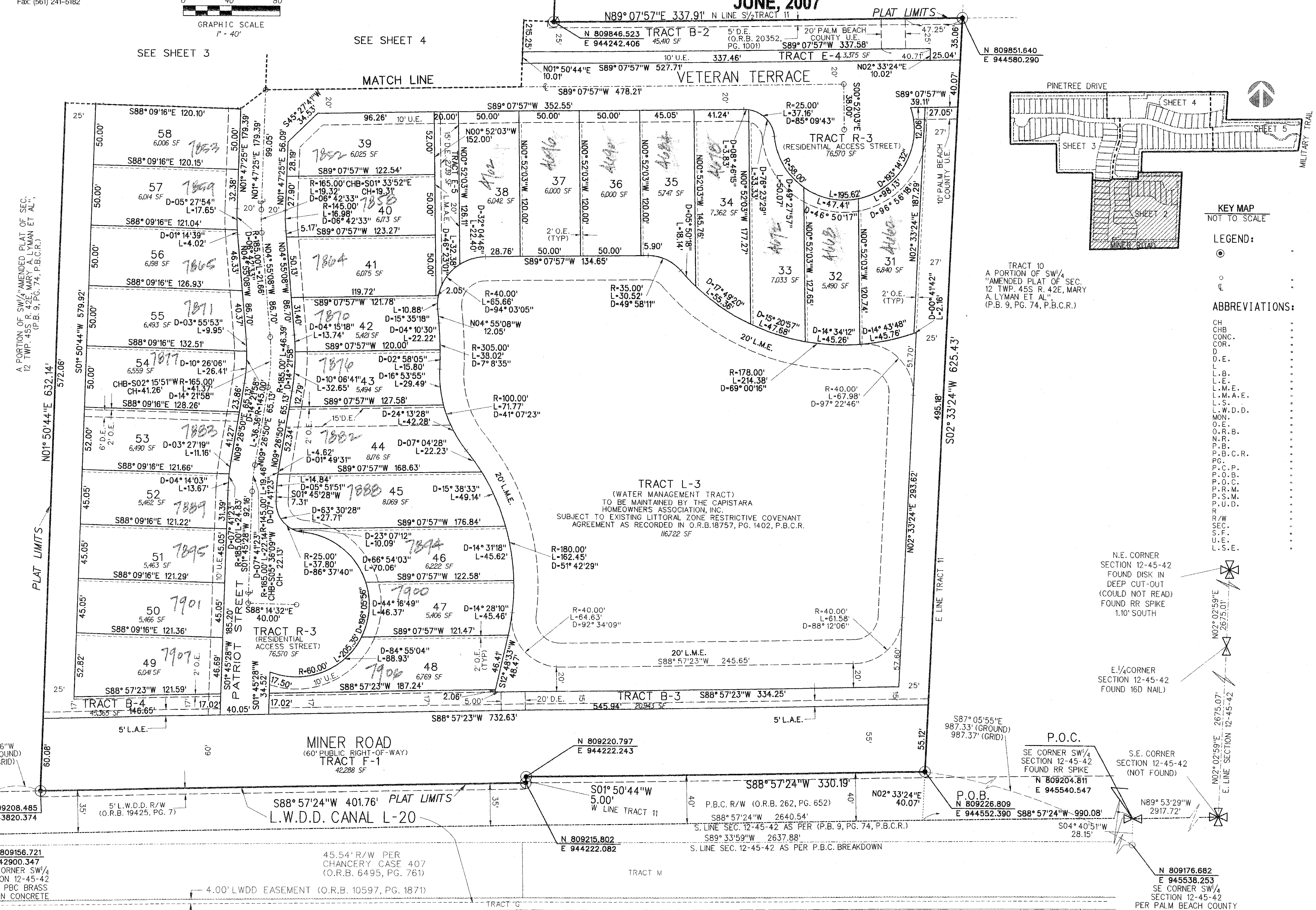

- LEGEND:**
- CENTERLINE
 - CHORD BEARING
 - CONCRETE
 - CORNER
 - DELTA (CENTRAL ANGLE)
 - DRAINAGE EASEMENT
 - ARC LENGTH
 - LICENSED BUSINESS
 - LANDSCAPE EASEMENT
 - LAKE MAINTENANCE EASEMENT
 - LAKE MAINTENANCE ACCESS EASEMENT
 - LICENSED SURVEYOR
 - LAKE WORTH DRAINAGE DISTRICT
 - MONUMENT
 - OVERHANG EASEMENT
 - OFFICIAL RECORDS BOOK
 - NON-RADIAL
 - PLAT BOOK
 - PALM BEACH COUNTY RECORDS
 - PAGE
 - PERMANENT CONTROL POINT
 - POINT OF BEGINNING
 - POINT OF COMMENCEMENT
 - PERMANENT REFERENCE MONUMENT
 - PROFESSIONAL SURVEYOR & MAPPER
 - PLANNED UNIT DEVELOPMENT
 - RADIUS
 - RIGHT-OF-WAY
 - SECTION
 - SQUARE FEET
 - UTILITY EASEMENT
 - LIFT STATION EASEMENT
- ABBREVIATIONS:**
- CH CHORD BEARING
 - CHB CONCRETE
 - CONC. CONCRETE
 - COR. CORNER
 - DELTA (CENTRAL ANGLE)
 - DRAINAGE DRAINAGE EASEMENT
 - L. LICENSED BUSINESS
 - L.E. LANDSCAPE EASEMENT
 - L.M.A.E. LAKE MAINTENANCE ACCESS EASEMENT
 - L.S. LICENSED SURVEYOR
 - L.W.D.D. LAKE WORTH DRAINAGE DISTRICT
 - MON. MONUMENT
 - O.E. OVERHANG EASEMENT
 - O.R.B. OFFICIAL RECORDS BOOK
 - N.R. NON-RADIAL
 - P.B. PLAT BOOK
 - P.B.C.R. PALM BEACH COUNTY RECORDS
 - P. PAGE
 - P.C.P. PERMANENT CONTROL POINT
 - P.O.B. POINT OF BEGINNING
 - P.O.C. POINT OF COMMENCEMENT
 - P.P.M. PERMANENT REFERENCE MONUMENT
 - P.S.M. PROFESSIONAL SURVEYOR & MAPPER
 - P.U.D. PLANNED UNIT DEVELOPMENT
 - R. RADIUS
 - R/W RIGHT-OF-WAY
 - SEC. SECTION
 - S.F. SQUARE FEET
 - U.E. UTILITY EASEMENT
 - L.S.E. LIFT STATION EASEMENT

SURVEYOR: [Signature]
 BOOK: 10
 PAGE: 96
 PLAT: 96
 QUAD: 34
 SE: [Signature]
 TAZ: 400
 PUD: 96

14	15	16	17	18	19	20	21	22	23	24	25	26	27	28	29	30	31
----	----	----	----	----	----	----	----	----	----	----	----	----	----	----	----	----	----

GATEWAY GARDENS P.U.D.
(P.B. 84, PGS. 20-23)